

ROBOTS5

ELECTRO-MECHANICAL BREADBOARD (EMB) LM1 USER MANUAL



Version 2.20 - Jan.2025

ROBOTS5 LLC, USA



Disclaimer

- Be sure to read this document carefully and fully understand it, before using this product
- Be sure to read the “EMB Safety Document” carefully and fully understand it, before using this product
- Robots5 LLC is not responsible for any damage or injury caused by misuse, misunderstanding, or abuse of this product
- The user is solely responsible for the implementation of the controller and safety system used with our products
- This document was generated and completed to the best ability of Robots5 LLC. The information on this manual are presented in good faith and believed to be correct however, Robots5 LLC makes no warranties as to the completeness or accuracy of the information
- Never use our products in any application where failure of the product could result in personal injury. Failure to comply with these instructions could result in death or serious injury
- This equipment should not be used by inexperienced users, unless if they are under close supervision of experienced users. Safety operation must be ensured by experienced users
- Robots5 LLC reserves the right to make changes to this document or to the products described herein without further notice
- Make sure to always use the latest version of this document

Contact Information:

Email: info@robots5.com
Website: www.robots5.com
Location: Oviedo, FL USA

© 2025 Robots5 LLC., All Rights Reserved.



Safety

- If improperly used, EMB can cause injury or death
- Never touch any moving parts! Always stay clear from gears, sprockets, belts, chains, linkages, and any components in motion
- Never place fingers or hands between moving components and hard stops
- Follow all information and recommendations from this document and from the “EMB Safety Document”
- Do not disassemble or modify this device
- Responsible use of EMB is crucial to prevent dangerous conditions
- Make sure to disconnect power when handling this device
- Only use this device in indoor applications, with no water/oil splash or contact. Never operate EMB near explosive gases or flammable liquids
- Treat this device with care, it is a precision unit. Do not throw, hit, or drop it
- If you notice the unit getting warm or hot or making abnormal noises or vibrations, or sense smoke, immediately stop all motion and turn the power completely off. Assess the situation to completely understand the issue before attempting to resume operation
- Never hot-plug this module, turn off power before plugging it in or off
- Do not operate outside the specifications of the unit
- Do not plug the cable for the LM1 into the potentiometer port, damage will likely occur
- Powering this device outside the electrical rating will damage it
- Do not touch the linear encoder strip, encoder head, and internal wires



Fingers may break or get amputated if caught in moving parts!

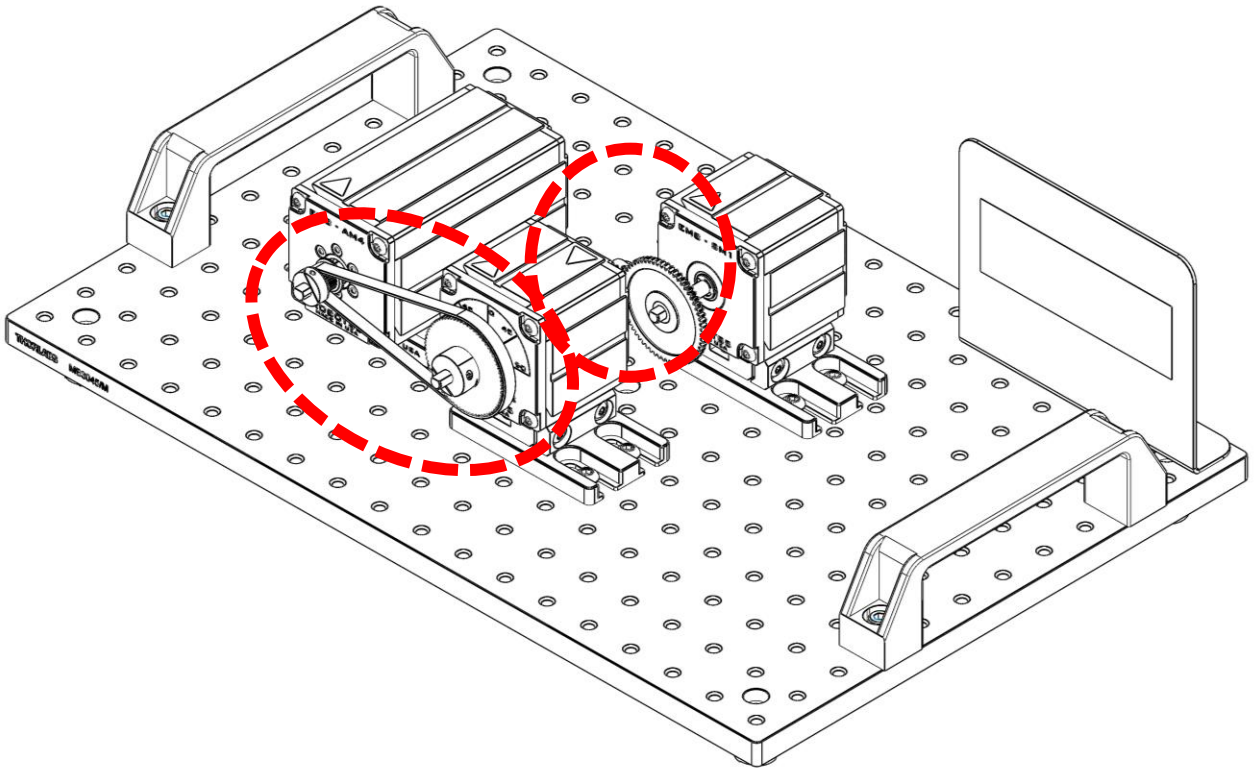

ALWAYS KEEP HANDS AWAY FROM MOVING PARTS!

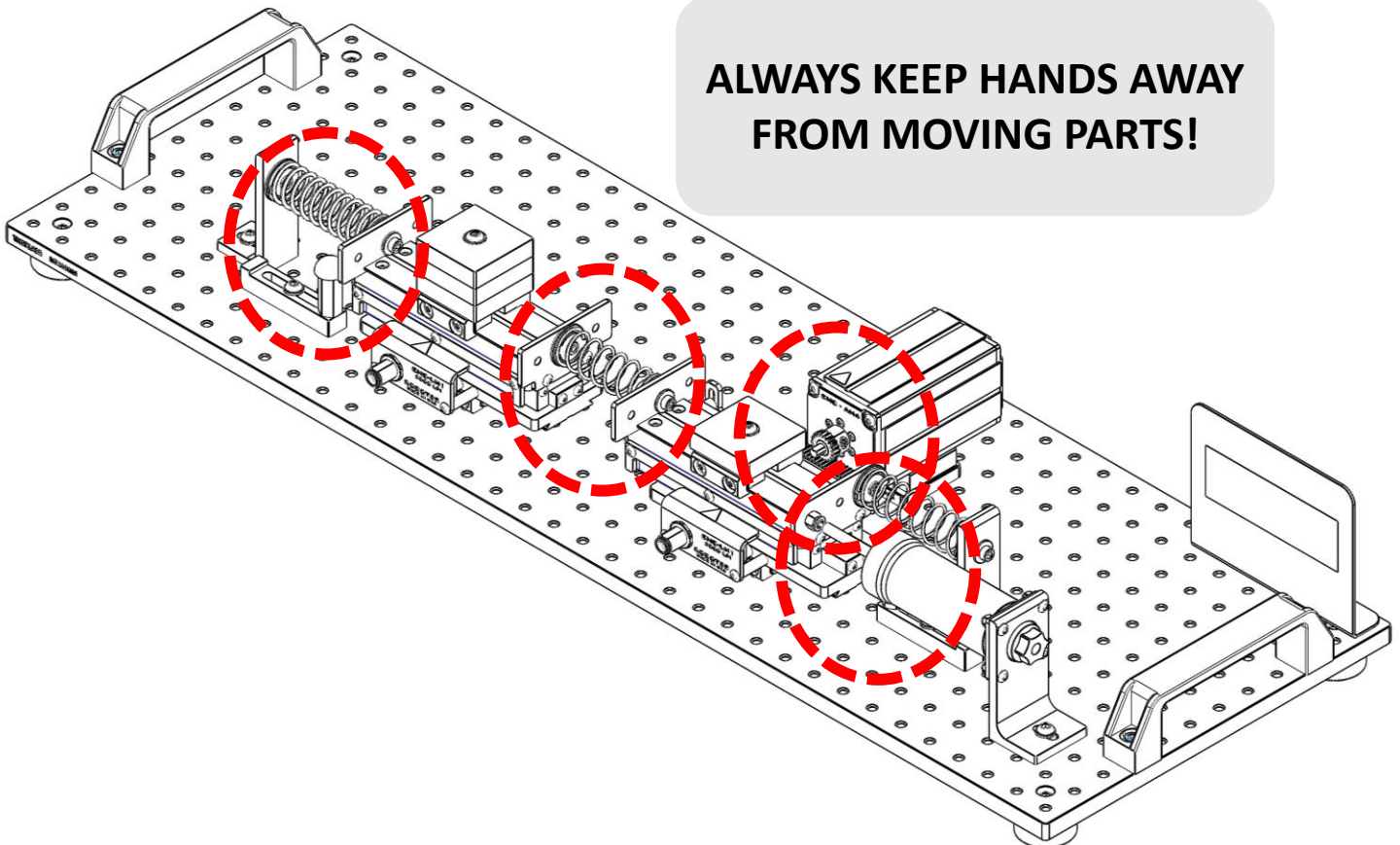

Introduction

The EMB-LM1 is a linear slide with an integrated optical linear incremental encoder. The encoder is used to measure relative displacement.

This module is designed to interface with other EMB modules via components mounted to the dovetails and side/rear tapped holes. Examples of components that can be mounted to the carriage via the tapped holes include the rack attachment, belt attachment, cam attachment, and brake attachment. Examples of components that can be mounted to the carriage via the dovetail include the pendulum attachment, dovetail clamp mount, and accelerometer module.

The anodized aluminum body of the EMB-LM1 module relies on a dovetail approach for precision locating and firmly securing to breadboard or dovetail rail by the use of a clamp.

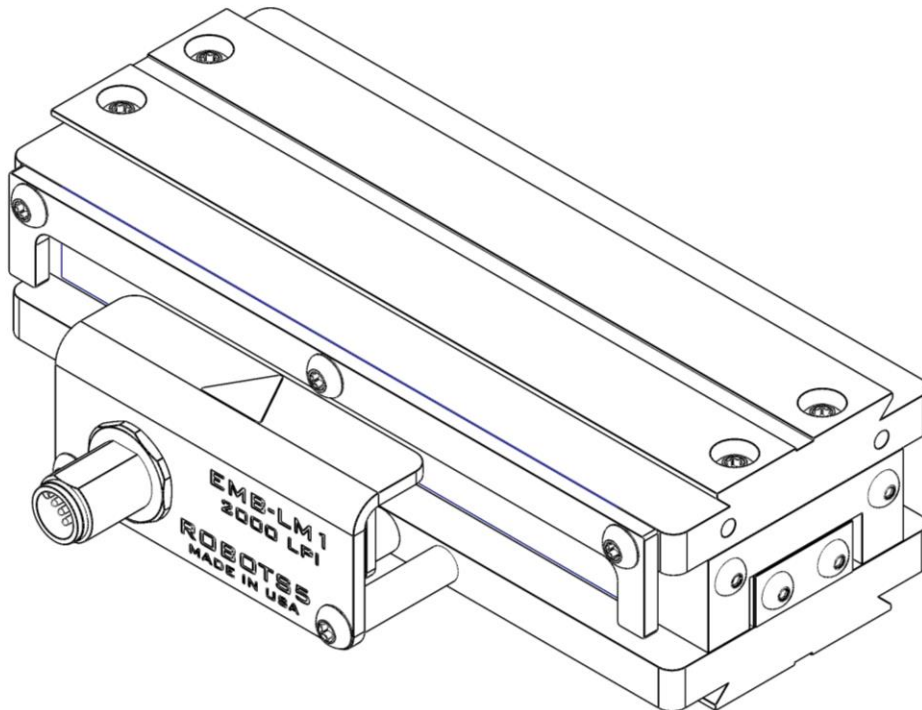

Figure 1: EMB-LM1 Module

The key features of the EMB-LM1 are presented bellow:

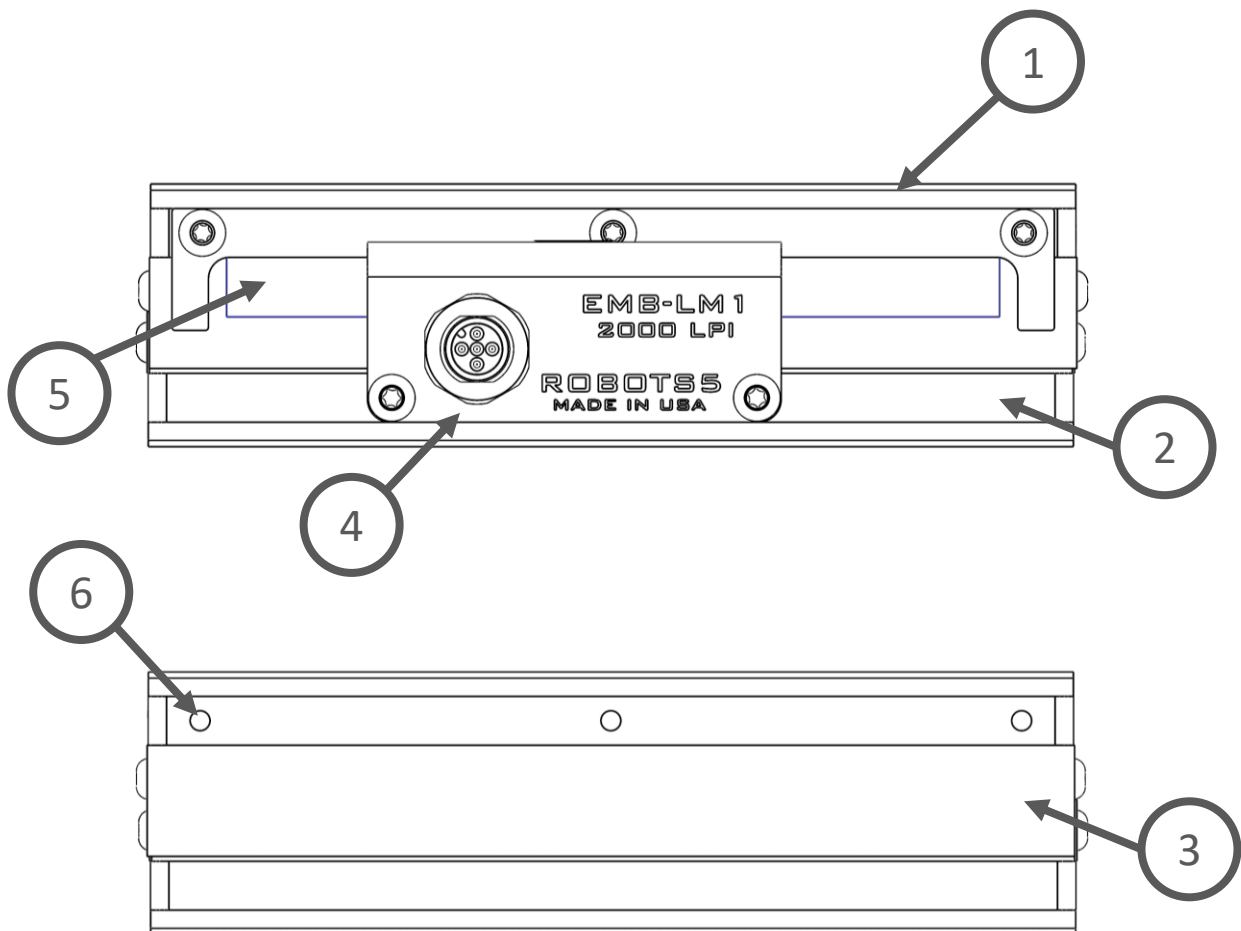

Figure 2: EMB-LM1, front and rear views

Item	Feature
1	Carriage dovetail (moving)
2	Base dovetail (fixed)
3	Low friction ball slide
4	M12, 5 Pole Connector
5	Linear encoder strip
6	M4x0.7 mounting holes for attachments, 7 total

Table 1: Key features of the EMB-LM1

Specifications

The EMB-LM1 relies on a low friction ball slide and on a single-ended optical incremental. It performs a relative linear measurement, not an absolute measurement like a potentiometer.

Table 2 describes the linear slide mechanical data.

Parameter	Value	Units
Mechanical Travel	100	mm
Mechanical Travel	Continuous	-
Max. Load	250	N
Accuracy ¹	0.013	mm/25mm of travel
IP Rating	IP40	-
Body Material	Aluminum	-
Friction Coefficient ¹	0.003	-
Weight	0.92	kg
Carriage weight (moving)	0.52	kg

Table 2: EMB-LM1 mechanical data

¹ = provided by bearing manufacturer

Figure 3, shows the general dimensions of the module:

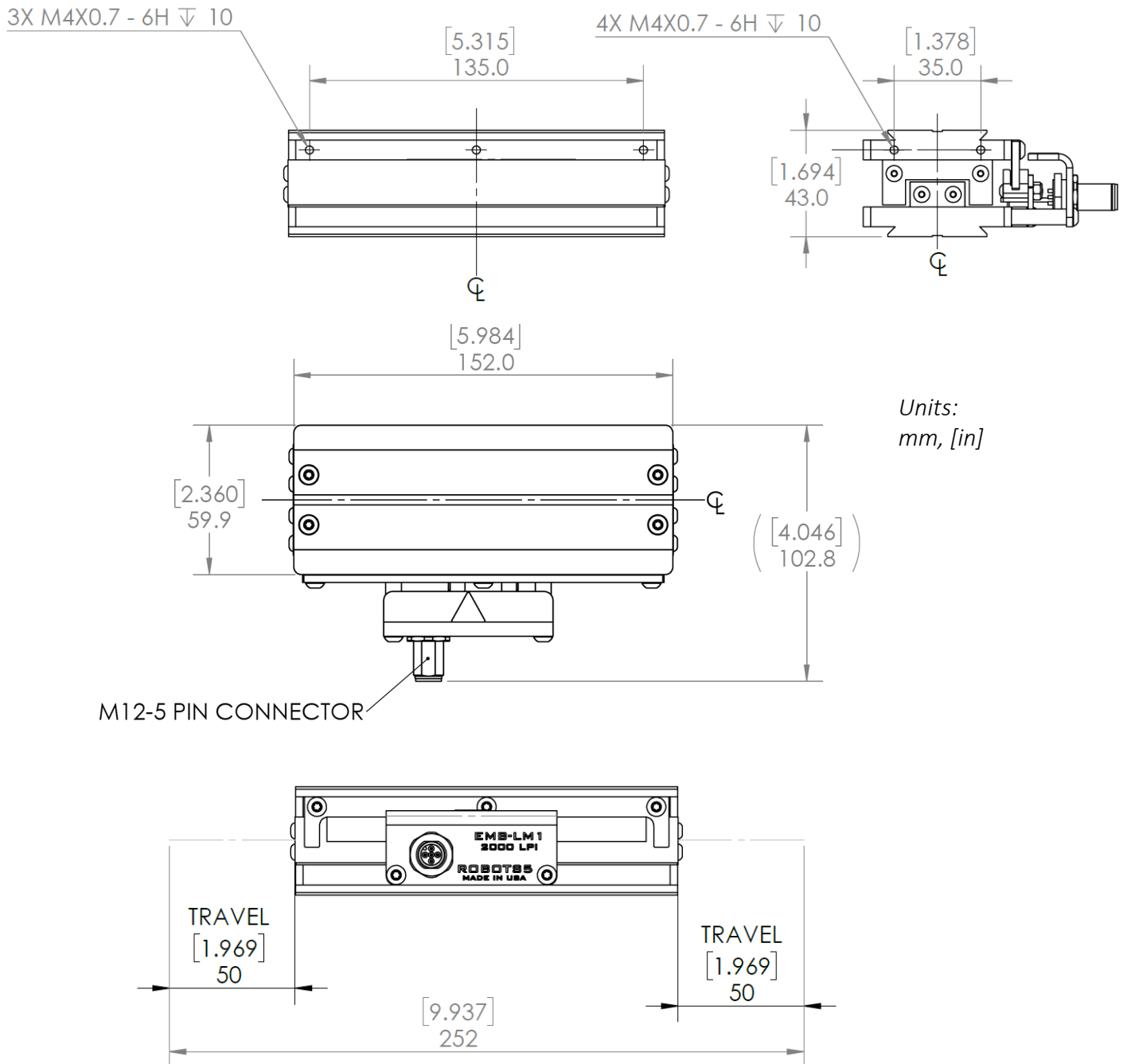

Figure 3: EMB-LM1, general dimensions

The dovetail profile matches the XT66 66mm optical construction rails from Thorlabs.

There are several mounting options to interface with the dovetail, including XT66C4, XT66C2, and XT66P3 from Thorlabs.

The carriage has a total of seven M4x0.7 tapped holes for the user to mount attachments. There are 3 on the rear side of the module, and 2 on each side.

End plates can be mounted on the sides of the modules, to connect springs, dampers, and other mechanisms.

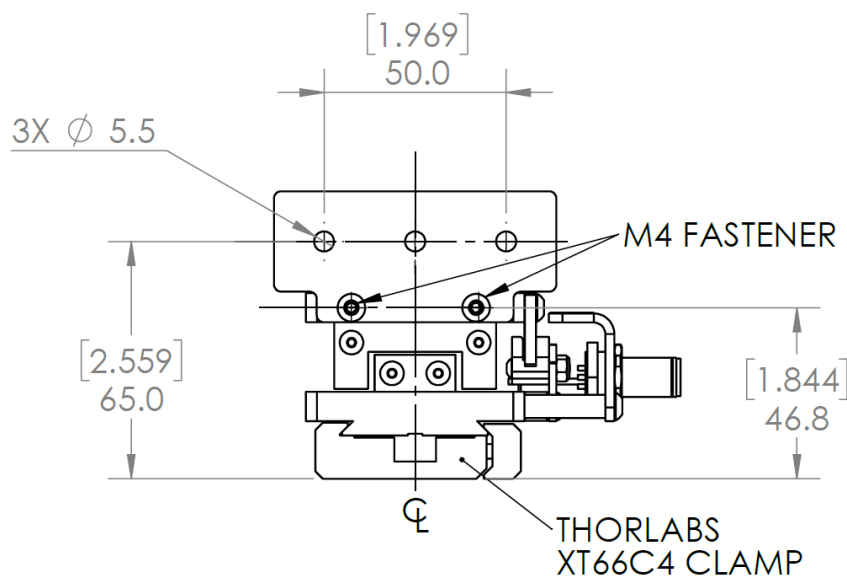

Figure 4: EMB-LM1, end plate dimensions

The internal hard stops of the linear bearing are designed simply to prevent the bearing balls from falling out, they are not designed to handle impacts. Impacts in the internal hard stop will result in permanent damage to the module.

The user must provide an external hard stop to properly constraint end of travel motion, for both sides. We recommend at least 10 millimeters of buffer, between the internal hard stop and the external hard stop.

The contact surface must be compliant (for instance, rubber) so the impact doesn't damage the contact surfaces of the EMB-LM1 module and external hard stops. Robots5 offers hard stops with adjustable mounts to accommodate plant designs.

The standard lines per inch (LPI) for the EMB-LM1 is 2000 LPI. In quadrature mode, the encoder has a resolution of 8000 counts per inch.

We can also supply the EMB-LM1 module with different LPI counts, if your application requires (ranging from 120 LPI to 2000 LPI).

The index signal is approximately aligned with the center line (CL) of the module.

Be extremely careful with the linear encoder strip. Avoid touching it as it can bend the Mylar™ polyester film and permanently get damaged.

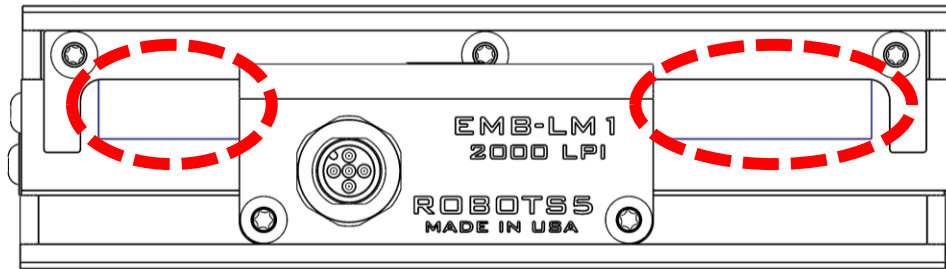

Figure 5: EMB-LM1, linear encoder strip

This encoder offers 2 channel quadrature TTL squarewave outputs. In addition, it has an index channel.

Table 3 describes the electrical specifications:

PARAMETER	MIN.	TYP.	MAX.	UNITS	CONDITIONS
Supply Voltage	4.5	5.0	5.5	V	
Supply Current	27	33		mA	CPR < 500, no load
	54	62		mA	CPR ≥ 500 and < 2000, no load
	72	85		mA	CPR ≥ 2000, no load
Low-level Output		0.5		V	I _{OL} = 8mA max., CPR < 2000
		0.5		V	I _{OL} = 5mA max., CPR ≥ 2000
	0.25			V	no load, CPR ≥ 2000
High-level Output	2.0			V	I _{OH} = -8mA max. and CPR < 2000
	2.0			V	I _{OH} = -5mA max. and CPR ≥ 2000
	4.8			V	no load and CPR < 2000
	3.5			V	no load and CPR ≥ 2000
Output Current Per Channel	-8	8		mA	CPR < 2000
	-5	5		mA	CPR ≥ 2000
Output Rise Time	110			nS	CPR < 2000
	50			nS	CPR ≥ 2000, ± 5mA load
Output Fall Time	100			nS	CPR < 2000
	50			nS	CPR ≥ 2000, ± 5mA load

Table 3: Encoder electrical data, from US Digital

Connections

Figure 6 and Table 4, show the pin out of the connector:

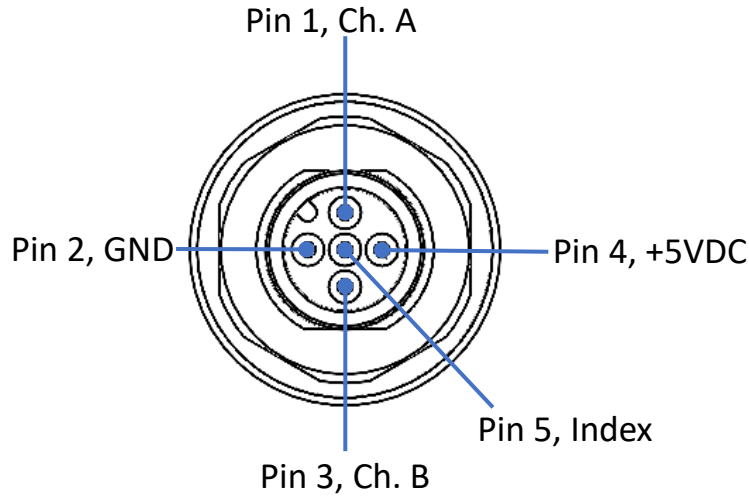

Figure 6: EMB-LM1, pin out

Pin	Signal	Wire Color ¹
1	Ch. A	Brown
2	GND	White
3	Ch. B	Blue
4	+5VDC	Black
5	Index	Gray ²

Table 4: Encoder pin out

¹ = for Murrelektronik cables

² = or green

Don't touch the internal wires and encoder head, this can damage the module.

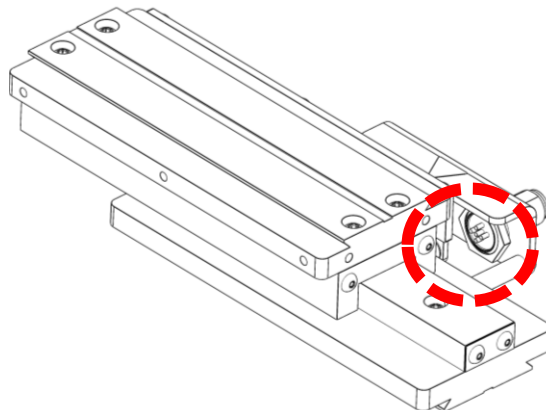

Figure 7: EMB-LM1, linear encoder head and wires

Connection to the EMB-LM1 is made through the Murrelektronik M12-5 pole connector. This is a standard industrial connector type.

There are several options for cables, including:

Murrelektronik PN	Feature
7000-40041-0250100	M12 axial Male to M12 axial Female, 5-pole, length 1m
7000-40041-0250300	M12 axial Male to M12 axial Female, 5-pole, length 3m
7000-12241-0250300	M12 axial female to pigtail, 5-pole, length 3m
7000-12361-0250300	M12 right-angle female to pigtail, 5-pole, length 3m
4-Pole Cables	
7000-40021-0240100	M12 axial Male to M12 axial Female, 4-pole, length 1m
7000-40021-0240300	M12 axial Male to M12 axial Female, 4-pole, length 3m
7000-12221-0240200	M12 axial female to pigtail, 4-pole, length 2m
7000-12341-0240200	M12 right-angle female to pigtail, 4-pole, length 2m

Table 5: Cable options

Note, using a 4-pole cable won't supply the Index signal, since the center pin of the 5-pole connector won't be connected.

The maximum cable length allowed, to keep a good signal integrity is 3m. We recommend using a shorter (1m) cable if your application allows.

If you are using a pigtail option cable, making an incorrect connection or shorting the leads will likely permanently damage the module.

Have questions or need additional support?

Contact us at:

Web: www.robots5.com

Email: info@robots5.com

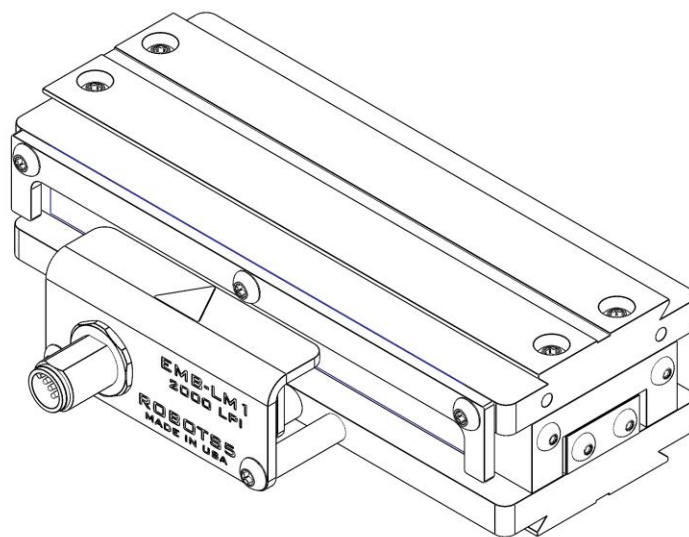

ROBOTS5